

Welcome

With the INTUITY™ AUDIX® messaging system, you have the following capabilities using your telephone:

Voice Mail

You can record voice messages in advance and send them to the mailboxes of other users without actually calling their telephones.

Other users also can record and send voice mail messages directly to your mailbox. When convenient, you can access your mailbox to get those messages.

Call Your Mailbox

Your mailbox stores incoming and outgoing voice, fax, text messages, or multimedia messages and headers. Your mailbox stores messages by their status (see the figure entitled "Your Voice Mailbox").

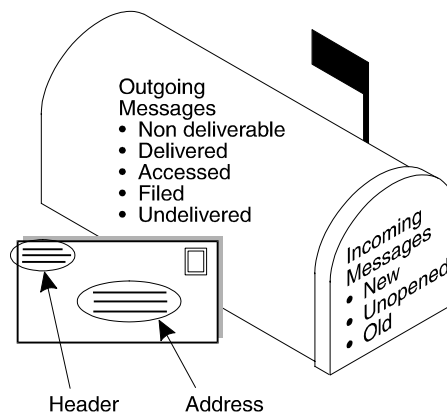

Your Voice Mailbox

To call the first time, pick up your phone and enter:

1. Your system-access number. Ext XXXX. If you are off-site XXX-XXX-XXXX.
2. Your extension, followed by #.
3. Your default password, followed by #.

Get Around in Your Mailbox

When you call your mailbox and login, you reach the Main Menu. The Main Menu is also referred to as the Activity Menu.

Main Menu Options

- 1 Record and send messages
Create, address, and select delivery options for mail messages.
- 2 Get messages
Listen to, respond to, print, and delete messages.
- 3 Create greetings
Create, change, and activate personal greetings.
- 4 Outgoing and filed messages
Determine the status of and listen to messages you previously created.
- 5 Personal options
Set up mailing lists, recorded name, and password.
- 7 Autoscans
Scan messages by pushing just two buttons.

Voice Prompts and Help

After you log in, *the voice prompts always tell you what to do.*

- For *help* at any time, press * **H** (* **4**) to get a list of your *current* options, or
- To return to the Main Menu, press * **R** (* **7**).

Basic Commands

- * **4** (or * **H**) Help
- * **7** (or * **R**) Return to Main Menu
- * **9** (or * **W**) Wait
- ** **9** (or ** **X**) Exit system
- * **3** (or * **D**) Delete
- ** **8** (or ** **U**) Undelete
- ** **4** (or ** **H**) Hold message in category
- ** **7** (or ** **R**) Log in again

Use while listening to messages

- 9 Increase speed
- 8 Decrease speed
- 4 Increase volume
- 7 Decrease volume

- 6** Skip forward
- 5** Skip backward
- * 6** Skip to next message component
- * 5** Skip to previous message component

Use while addressing

- * 2 (or * A)** Alternate between name and number addressing
- * 5 (or * L)** Use mailing list for addressing

Change Your Password

Your system administrator establishes your default password. Change this password *immediately* after you login the first time.

To change your password:

1. Press **5 4** from the Main Menu.
2. Enter the new password (up to 15 digits the minimum is 6), followed by **#**.
3. Re-enter the new password again, followed by **#**.



SECURITY ALERT:

Don't use a password that uses:

- Ascending or descending digits (for example, 1234 or 4321)
- The same digits (for example 0000)
- Digits matching your name or initials (for example, 5646 for John)
- The current year (for example, 1996)
- The same number as your extension (for example, extension 3455, password 3455)
- A reverse extension (for example, extension 3455, password 5543)
- Numbers that identify you, such as your social security number, employee ID, room number, or department
- A programmable function key or speed-dial key

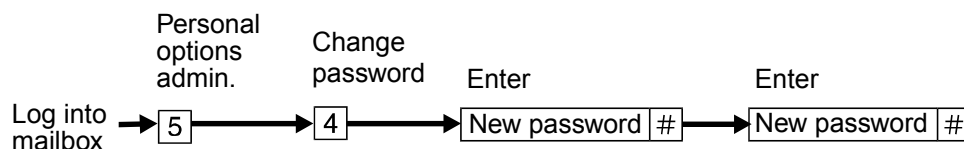

Change Password

Record Your Name

Record your name to replace the system greeting for your mailbox. Callers hear your voice and feel comfortable they have reached the right person.

To record your name:

1. Press **5 5** from the Main Menu. Speak your name after the tone.
2. Press **1** to stop.
3. **(Optional):** One of the following:
 - 1** Re-record.
 - 2 3** Play back.
4. Press **#** to approve.

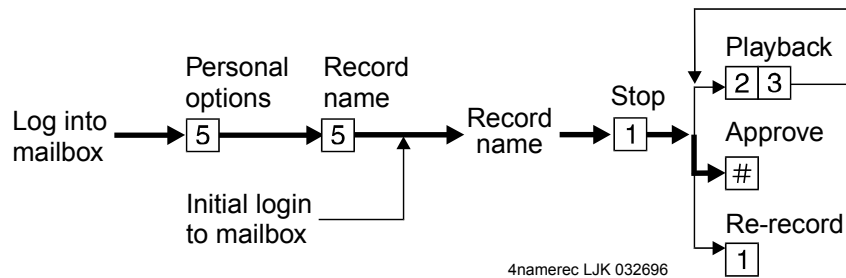

Record Your Name

Record a Greeting for Callers

When you don't answer your telephone, the system works just like an answering machine. The system sends the call to your mailbox. Then, the caller either hears a system greeting or a greeting you've recorded.

You can record and store several personal greetings, each for a specific situation. You can manually activate each greeting as needed, or you can keep a number of greetings active at once (see "Create and Use Multiple Personal Greetings").

Recording Your Basic Greeting

To record your basic greeting:

1. Press **3 1** from the Main Menu. Speak your greeting at the tone. You may need to enter a greeting number before you speak your greeting.
2. **(Optional):** Press one of the following:
 - 1** Pause (and 1 again to continue recording).
 - 2 3** Play back.

* 3 (* D) Delete and begin again.

3. Press # to approve. Do one of the following:

- Follow the prompts to activate the greeting.
- Press # to leave the greeting inactive.

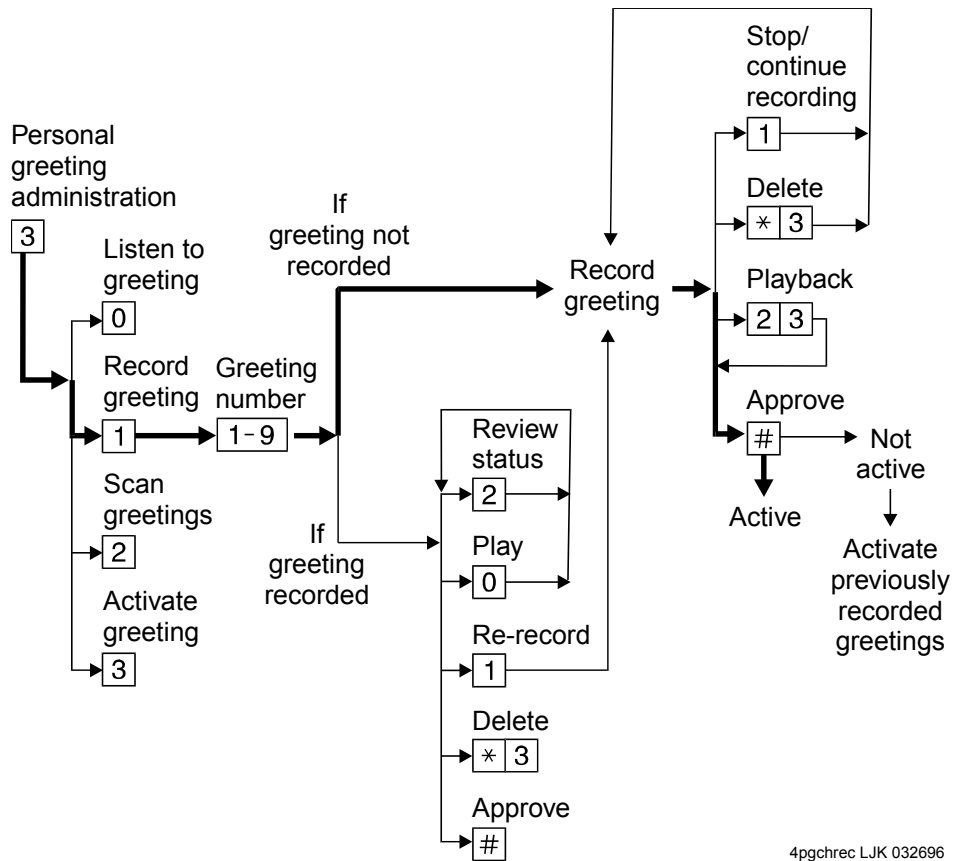

4pgchrec LJK 032696

Record Basic Greeting

Get Messages You've Received

You can listen to:

- Message headers, which tell you:
 - * Message type(s) -- voice, fax, text, and/or binary file
 - * Who sent the message
 - * When the message was sent and how big it is
- Voice messages

A cover page is included when you print. It lists the size of each component of a message, including the size of attached files. You can view an attached file only by using Message Manager.

Listening to a Voice Message

1. Press **2** from the Main Menu. Listen to the header of the first message. If the system or your mailbox is not activated to receive messages of all media, the header may say that a message is "incomplete." In this case, contact the sender to find out what you failed to receive.
2. Press any of the following:
 - 0** Listen to the voice or text message, if any. Press **0** again to rewind and listen from the start.
 - 2** Rewind to the start of the message. Press *** 2** to skip to the previous message.
 - 3** Play back the header after pressing **2**.
 - * 1** Print the fax, or text message, if any. See "Printing Fax/Text Messages".
 - 9** Increase speed
 - 8** Decrease speed
 - 4** Increase volume
 - 7** Decrease volume
 - 6** Skip forward
 - 5** Skip backward
 - * 6** Skip to next message component
 - * 5** Skip to previous message component

Responding to a Message

3. **(Optional):** Press **1**, and one of the following:
 - 0** Call the sender. In this case, you exit your mailbox.
 - 1** Reply to the sender by voice mail.
 - 2** Forward with comment at the beginning.
 - 3** Forward with comment at the end.
 - 4** Record and address a new message.

If you press any key other than **0**, continue with Steps a, b, and c.

- a. Record and address your message, if necessary. See Step 4 in "Sending a Voice Message". (If you're replying to the sender, you don't need to address the message.)
- b. Press **#** to approve, if necessary.
- c. Press **#** to send, or enter a delivery option, then press **#**. See "Enhanced Delivery Options".

Acting on a Message

4. Press one of the following:

- * **D** (* **3**) Delete the message.
- ** **U** (** **8**) Undelete the message.
- #** Save and skip to the next message.
- ** **H** (** **4**) Hold the message in the current category and skip to the next message.
- * **#** Skip to the next message category.

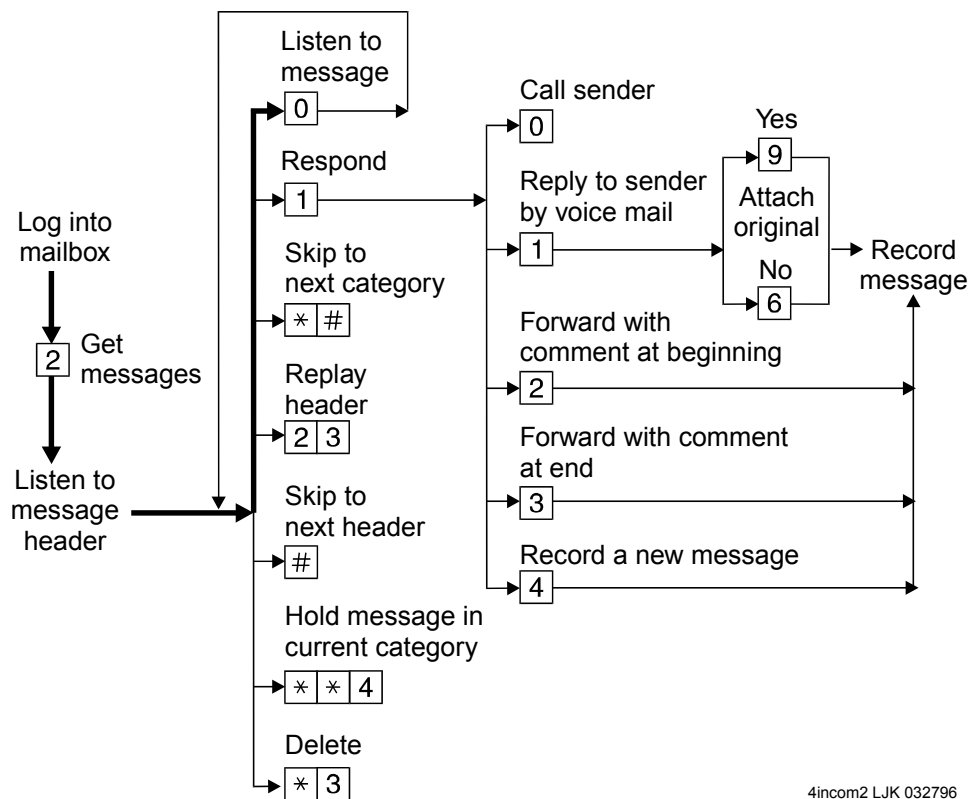

4incom2 LJK 032796

Get and Respond to Messages

Record and Send Messages

Sending voice, fax, and voice-fax messages from your mailbox are similar tasks, but there are *important* differences:

- You can record and send a voice message from any telephone.

Sending a Voice Message

1. Press **1** from the Main Menu.
2. Record your voice message at the tone.
 (Optional): To edit, press one of the following:
 - 1** Pause. Press **1** again to continue recording.
 - 2 3** Playback.
 - * D (or * 3)** Delete (and begin again).
3. Press **#** to approve the message.
4. To address, select one or more of the following:

- Enter the user's extension and press **#**.

If the user is in a different location, you may need to also add a prefix.

- Press ***2**. Spell out the user's name on the telephone keypad and press **#**. You can switch back and forth between addressing by extension and addressing by name by pressing ***2**.
 - To send to a mailing list:
 - a. Press *** L** to access a list.
 - b. Enter the list owner's extension and press **#**.
If you're the owner, press **#**.
 - c. Enter the list ID (name) and press **#**.
5. Press **#** to approve the address.
 7. Press **#** to send. Or, enter other options, and press **#** to send. See "Enhanced Delivery Options" later in this book.

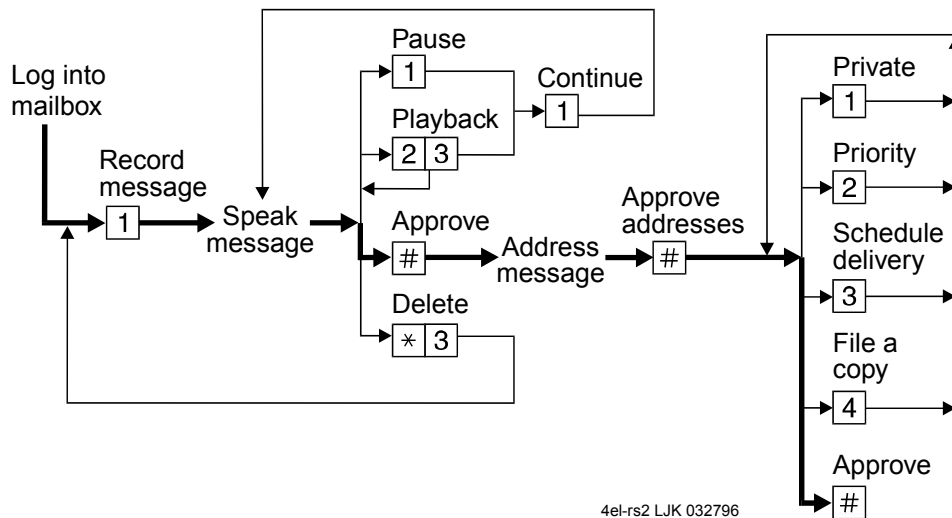

Recording and Sending Messages

Enhanced Delivery Options

When you have created/addressed a message and are ready to send, several delivery options are available. Select any of the following:

- 0** Review delivery options
- 1** Make your message private. (Press **1** again to undo.)

 NOTE:

The person receiving a private message can't forward it.

 NOTE:

The system cannot deliver a private message to an email user.

- 2** Make your message priority (if available). (Press **2** again to undo.)

 NOTE:

The system places a priority message in a mailbox ahead of all other messages, regardless of when the other messages were received.

- 3** Schedule delivery. (Press **3** again to undo.)

To schedule delivery:

- a. Enter the delivery time (405 = 4:05).
- b. Enter **2 (A)** for AM or **7 (P)** for PM and press **#**.
- c. Enter month and day of delivery (502 = May 2nd) and press **#**.
- d. Press **#** to approve or *** 3** (or *** D**) to start over.

- 4** File a copy. (Press **4** again to undo.)

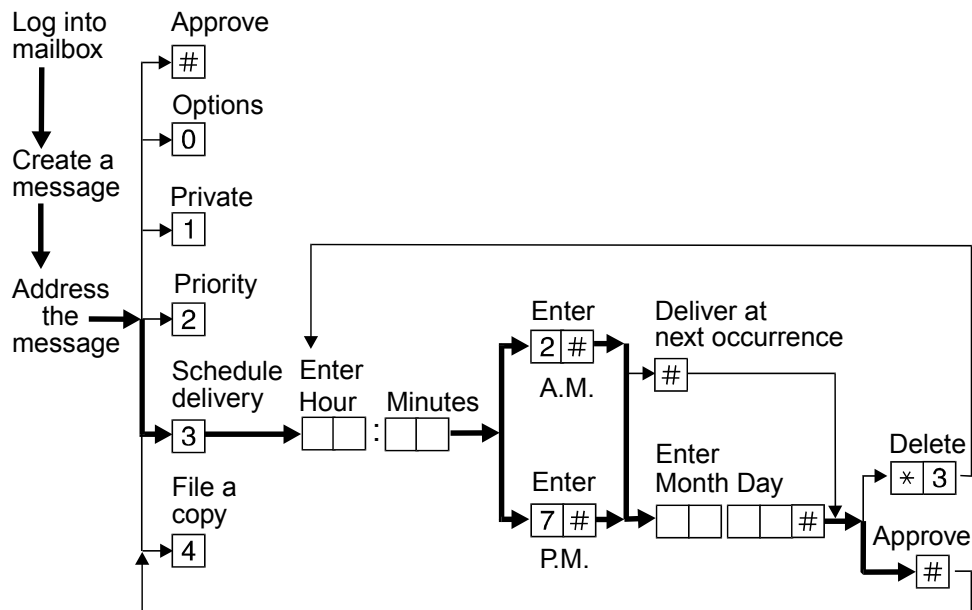

4delsch2 CJL 032796

Enhanced Call Delivery

Create Mailing Lists

A mailing list is a list of users to whom you might send a message simultaneously. A mailing list can save you a lot of time if you periodically send messages to the same group or groups of people.

1. Press **5 1 1** from the Main Menu.
2. Enter the list ID (up to six letters or digits) and press **#**.
3. Press one of the following:
 - 1** Make the list private.
 - 2** Make the list public.
4. Enter an address and press **#**.
If the user is in a different location, you may need to add a prefix to the extension.
5. Repeat Step 4 until the list is complete.
6. Press **#** to approve.

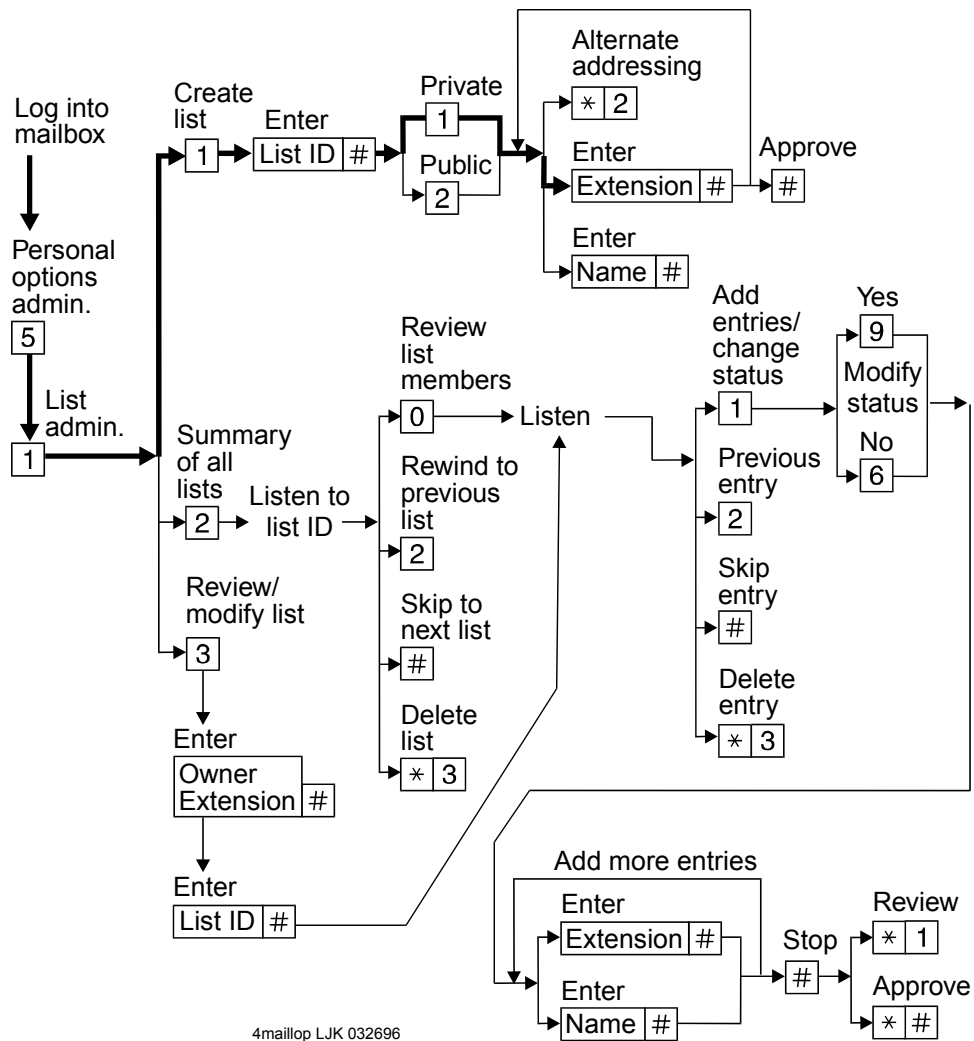

Create a Mailing List

Deleting Addresses from a List

There are two ways to delete addresses:

Review the list until you find an address, then press *** D (* 3)** or

- At step 4 (when creating a list), enter the address again and press *** D (* 3)**

➡ NOTE:

Though it appears that you have added a recipient twice, by deleting that number immediately after you add it, it will be deleted.

Repeat for other addresses.

Scanning List Summaries

1. Press **5 1 2** from the Main Menu.

2. Listen to the list summary.
3. Press any of the following:
 - #** Skip to next list.
 - * D (* 3)** Delete the entire list.
 - 0** Review/modify list members. See "Reviewing and Modifying a List"

Reviewing and Modifying a List

1. Press **5 1 3** from the Main Menu.
2. Enter the list owner's extension and press **#**. (If you own the list, only press **#**.)
3. Enter the list ID and press **#**.
4. Listen to the first name, then press any of the following:
 - #** Skip to the next name.
 - * D (* 3)** Delete the name.
 - 2** Repeat the name.
 - 2 2** Return to the previous name.
 - * 1** Review from the beginning.
 - 1** Add entries or change public/private status, then do the following:
 - a. Press **Y (9)** or **N (6)** to change the status.
 - b. Enter the address
 - c. Listen to the name.
 - d. Repeat steps b and c for each addition.
 - * #** Stop reviewing/modifying specified entries.
5. Press **#** when finished reviewing.

Create and Use Multiple Personal Greetings

After you have recorded several personal greetings, you may want to assign those greetings to specific types of incoming calls. Besides the basic mode of using one greeting for all calls, you can set up specific greetings for:

- internal and external calls
- busy and no-answer calls
- prime-time internal, prime-time external, and out-of-hours calls
- prime-time busy, prime-time no-answer, and out-of-hours calls

The first step is to define the types of calls you want to differentiate; then move on to changing call-type definitions and assigning greetings to call types.

Call Types

Internal	Calls from inside your business location.
External	Calls from outside your business location.
Busy	Calls that come in when you're using your telephone line(s).
No answer	Calls that come in when you don't answer.
Out-of-hours	Calls that come in after standard business hours (as defined by your system administrator).

(You must activate weekend greetings manually.)

Defining Call Types the First Time

1. Press **3 4** from the Main Menu.
2. Press one of the following:
 - 1 Differentiate internal/external calls.
 - 2 Differentiate busy/no-answer calls.
3. Press one of the following:
 - 3 Differentiate out-of-hours calls.
 - 4 Make no distinction between prime time and out-of-hours calls.

Changing Call Types

1. Press **3 4** from the Main Menu.
2. Press any of the following:
 - 1 Differentiate internal/external calls.
 - 2 Differentiate busy/no-answer calls.
 - 3 Differentiate out-of-hours calls.
 - 4 Turn off out-of-hours differentiation.
 - 5 Use a single greeting for all calls (negate call-type definition).
3. Press **#** to approve, then see "Assigning Greetings to Call Types".

Assigning Greetings to Call Types

1. Press **3** from the Main Menu.
2. Listen to the summary of active greetings.
3. Press **3** to activate a greeting.
4. Enter a number (0 to 9) to indicate which greeting you want to assign to a call type.
5. Press any of the following:

- 1 Use the greeting for each call type.
 - 2 Use the greeting for internal (or busy) calls.
 - 3 Use the greeting for external (or no-answer) calls.
 - 4 Use the greeting for out-of-hours calls.
 - 5 Use a single greeting for all calls (negate call-type definition).
6. Press # to approve.
 7. Press * R (* 7) to return to the Main Menu.

 NOTE:

To set up different greetings strictly for prime-time and out-of hours calls, you must assign the same greeting to the two prime-time call types (internal/external or busy/no-answer) and a second greeting for out-of-hours calls.

Activating Previously Recorded Greetings

1. Press **3 3** from the Main Menu.
2. Enter the greeting number.
3. Listen to the prompts for instructions on activating call types.

Scanning All Greetings

1. Press **3 2** from the Main Menu.
2. Listen to the status of the first greeting.
3. Press any combination of the following:
 - 0** Listen to a greeting.
 - 1** Re-record a greeting.
 - * D (* 3)** Delete and skip to the next greeting.
 - 2** Return to the previous greeting.
 - #** Save and skip to the next greeting.
4. Press *** #** to quit scanning.

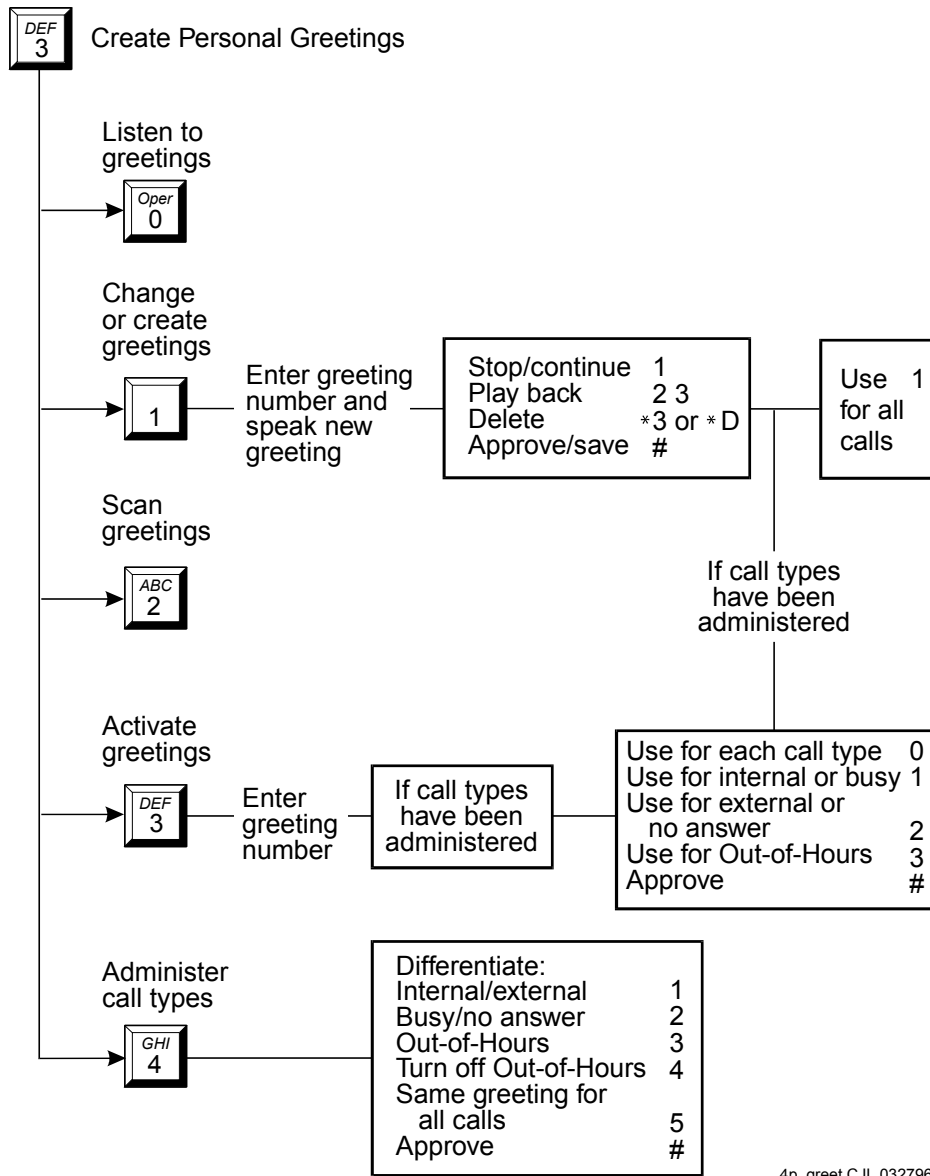

Create Multiple Personal Greetings

Check and Reuse Outgoing or Filed Messages

After you've sent a message, it progresses through a series of status categories. These categories are:

- Undelivered Not yet sent because it's scheduled for future delivery. You can listen to, re-address, and re-record the message prior to delivery.
- Delivered Delivered but not yet listened to.
- Accessed Delivered and listened to.

Undeliverable	Can't be delivered, usually because the recipient's mailbox is full. You can listen to, re-address, and re-record the message.
Filed	Copies and saves the outgoing message to re-send and/or modify.

You can check the status of outgoing messages. Or you can select, modify, and resend them.

Checking the Status of Messages You've Sent

To check the status of outgoing messages:

1. Press **4** from the Main Menu.
2. Listen to the first category and message header.
3. Press any or none of the following:
 - 0** Listen to the message.
 - 1** Modify/resend modified messages.
 - 2 3** Play back the message header.
 - * D (* 3)** Delete and skip to the next message.
 - 2 2** Return to previous messages.
 - #** Save and skip to the next message.
 - * #** Skip to the next message category.

NOTE:

For delivered or accessed messages, you can listen to the headers only. After you review an accessed message header, the system deletes the header automatically.

Changing and Resending a Message

4. Press **1** to change and/or re-send the selected message.
 - Press **#** to resend the message as is.
 - To change the message:
 - a. Press **1**.
 - b. Speak the message at the tone.
 - c. **(Optional):** To edit, press one of the following:
 - 1** Continue recording.
 - 2 3** Play back.
 - * D (* 3)** Delete (and begin again).
 - d. Press **#** to approve.

Resending a Message

5. For filed and undeliverable messages:

- a. Enter address(es) or list via * L (* 5).
- b. Press ## to approve and send immediately, or enter delivery options and press #.

For undelivered messages:

- a. Enter additional addresses and press #.
- b. Press * 1 to review and edit original addresses.
- c. Change delivery times or options.

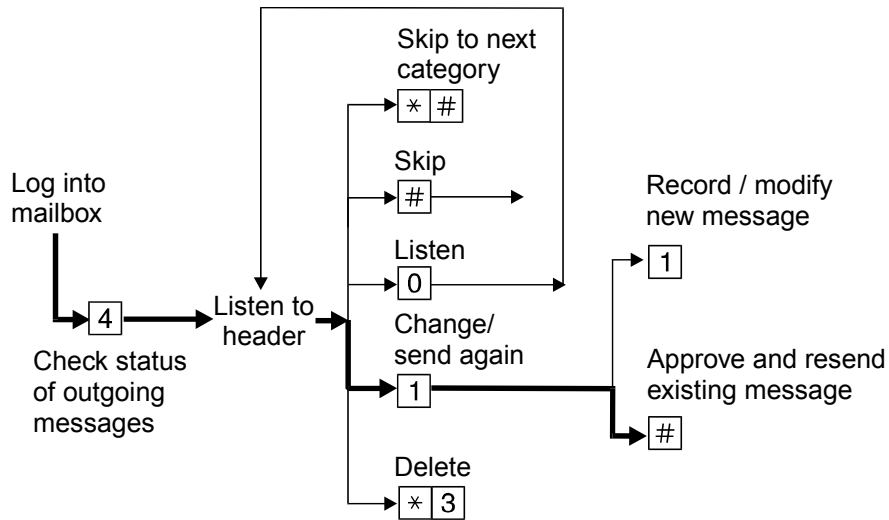

4existms CJL 032696

Checking Status of Messages You've Sent

Scan Messages Quickly

The autoscan option lets you get messages automatically with just 2 button presses. Autoscan is useful for car telephone users because it requires fewer button presses.

The autoscan option also lets you print all *new* faxes and text messages.

1. Press 7 from the Main Menu, then press:
 - 1 Scan headers and messages.
 - 2 Scan headers only.
 - 3 Scan messages only.
2. Use the *respond* and *act on* options as necessary.

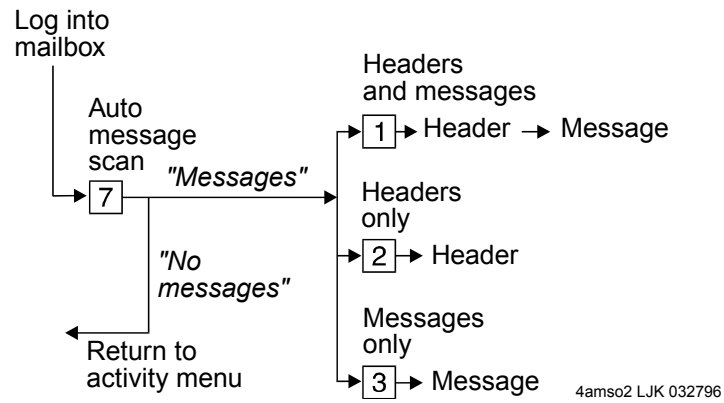

4ams02 LJK 032796

Autoscanning Messages